

# Physics at a Linear Collider

Yasuhiro Okada (KEK)

Pheno 04, April 28, 2004,  
Madison, Wisconsin

# Linear Collider Project

- Highest energy e+e- collider  
Ecm: up to 500 GeV in 1<sup>st</sup> stage , ~1TeV in 2<sup>nd</sup> stage
- Luminosity: above  $10^{34}/\text{cm}^2/\text{s}$ , (equivalent to a few  $\times 10^4$  Higgs bosons /year)
- Concurrent running with LHC

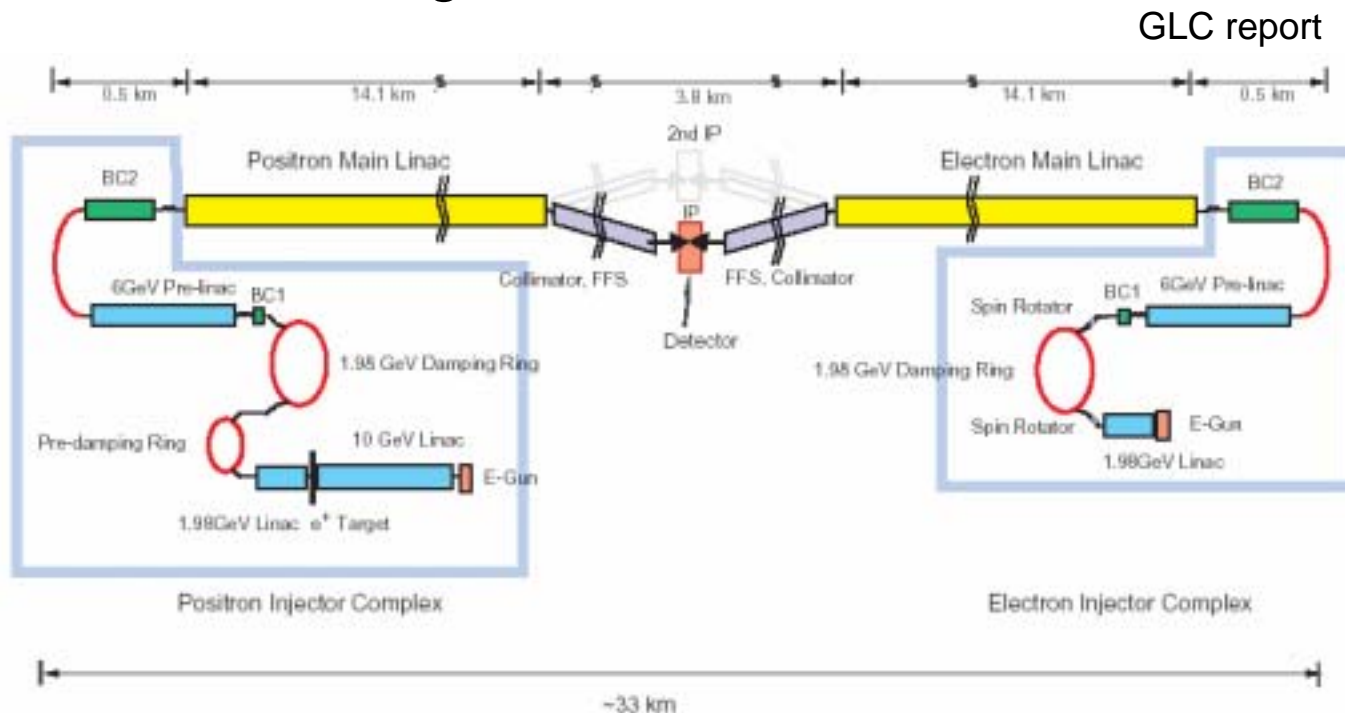

# Current understanding of particle physics

## ■ The Standard Model

Discovery of gluon, W, and Z bosons

Discovery of three generations of quarks and leptons.

Precise determinations of V-F-F, and V-V-V coupling constants.

CP violation in terms of Kobayashi- Maskawa mechanism

**No direct evidence on the Higgs mechanism**

# Hints of new physics

## 1. Unification ?

Gauge coupling unification in SUSY GUT

## 2. Neutrino mass

Seesaw mechanism?

## 3. Cosmological connection with particle physics

WMAP -> Dark matter candidate?

Baryon number of the Universe

## 4. Theoretical arguments

Hierarchy problem, Unification with gravity interaction, Superstring...

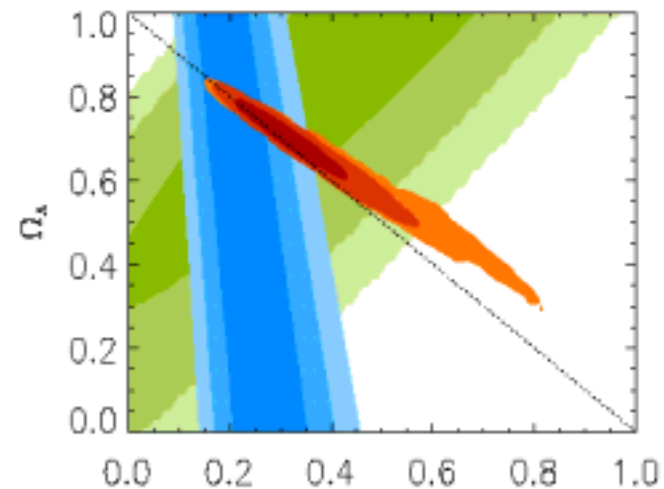
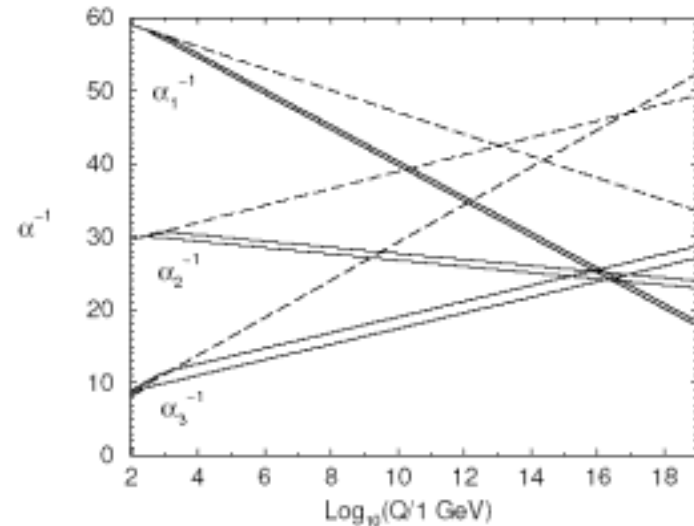

# Physics at LC

- Higgs physics ( Electroweak symmetry breaking and mass-generation)
- Direct signals of new physics (SUSY, Extra-dimensions, ...)
- Indirect search for new physics from precision study on gauge bosons, top and other fermion processes.

# Advantage of LC experiments

- $e^+$  and  $e^-$  are elementary particle (well-defined kinematics).
- Less background than LHC experiments.
- Beam polarization, energy scan.
- $\gamma - \gamma$ ,  $e^- \gamma$ ,  $e^- e^-$  options, Z pole option.

# Higgs Physics

- Global fits in SM indicate a light Higgs boson.
- SUSY and /or GUT predict a light Higgs boson.  
( $m_h < 135\text{GeV}$  in MSSM)
- LHC can cover the whole mass range of the SM Higgs boson.

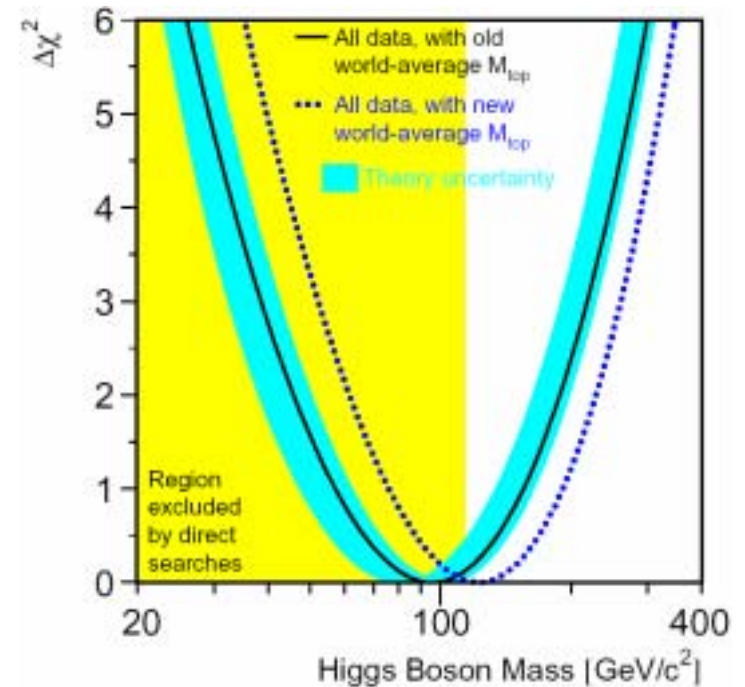
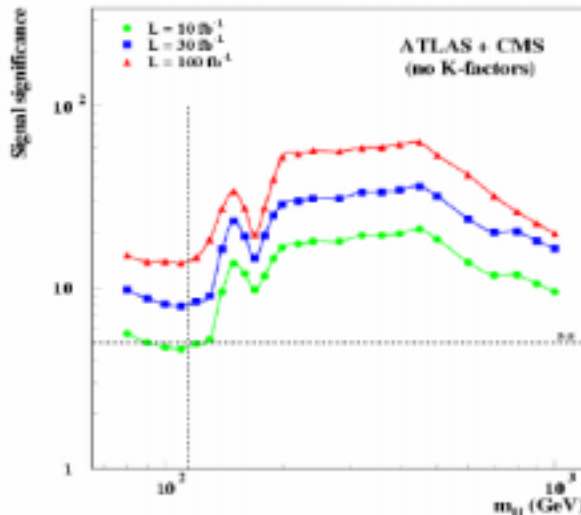

$$m_t = 178.0 \pm 4.3 \text{ GeV}$$

$$m_H < 251 \text{ GeV (95\%CL)}$$

LEP EW working group

# Higgs physics at LC

- Determination of spin and parity.
- Precise mass determination .  
( $\delta m_H \sim 40$  MeV for  $m_H = 120$  GeV)
- Detection of the Higgs boson independent of its decay property.  
(Recoil mass distribution in the HZ mode)
- **Coupling measurement**  
-> Mass generation mechanism of elementary particles.

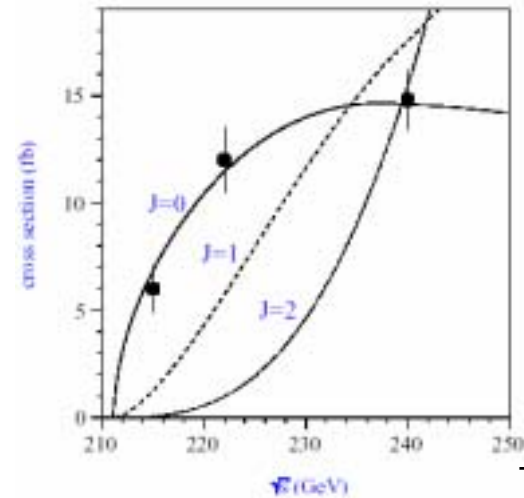
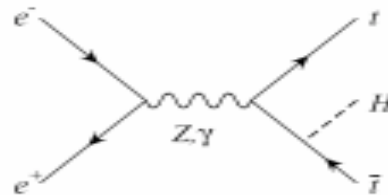
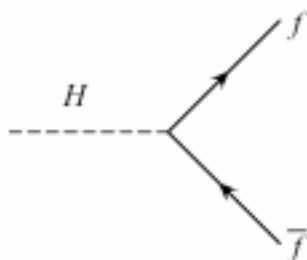
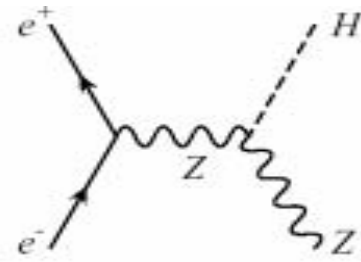
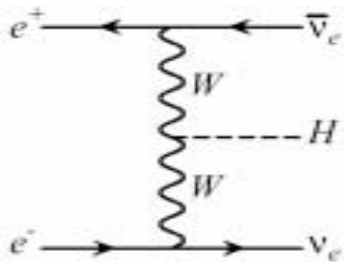

TESLA TDR

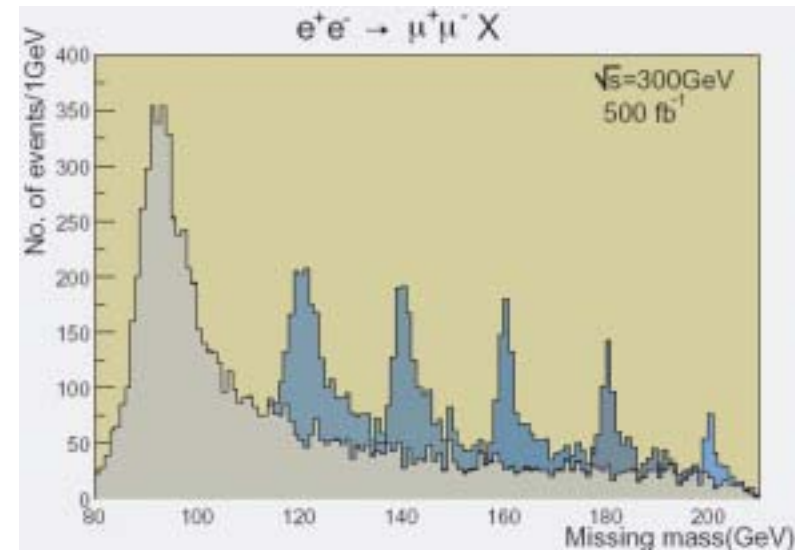

GLC report

# Higgs coupling measurement

LHC: O(10%) measurements for some ratios of coupling constants.  
 LC: O(1%) determination for various coupling constants.

Coupling-Mass Relation  
 LC: 300 – 700 GeV

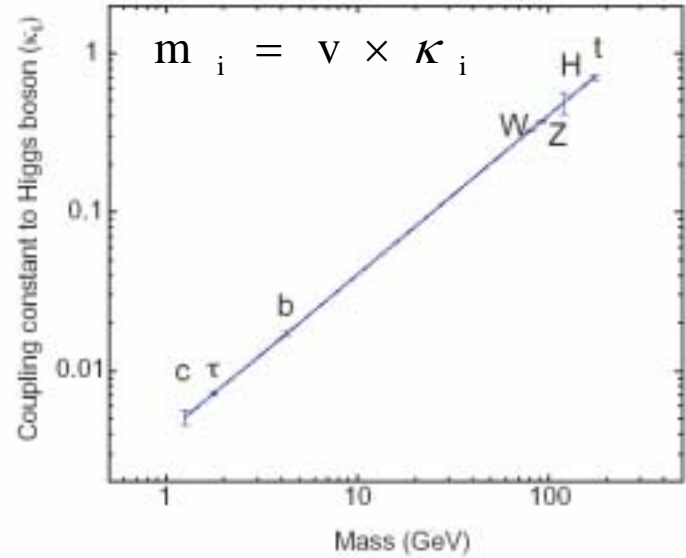

LHC

width ratios

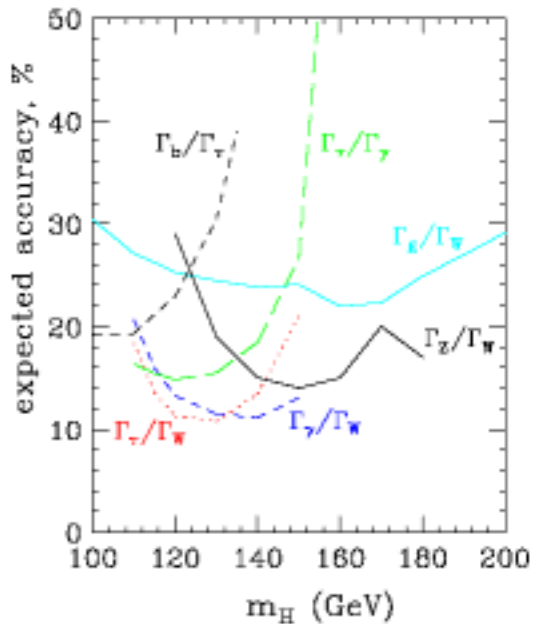

LC

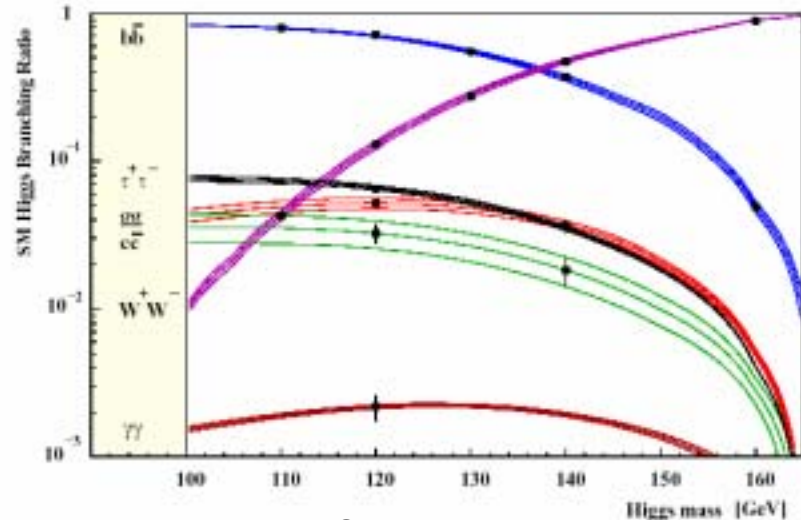

TESLA TDR

The Precision Higgs WG of Snowmass 2001



# SUSY loop contributions to the $hbb$ Yukawa coupling

$B(h \rightarrow bb)/B(h \rightarrow \tau\tau)$  is sensitive to the SUSY loop correction to the bottom Yukawa coupling for a large  $\tan\beta$  region.

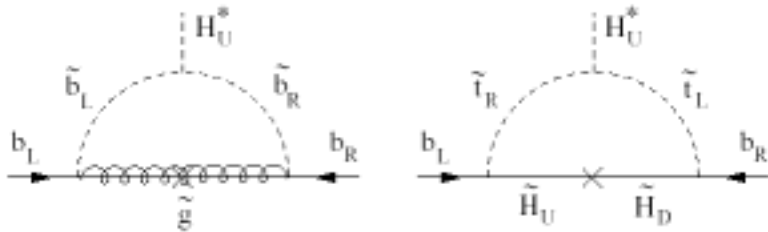

$B(h \rightarrow bb)/B(h \rightarrow \tau\tau)$  normalized by SM value

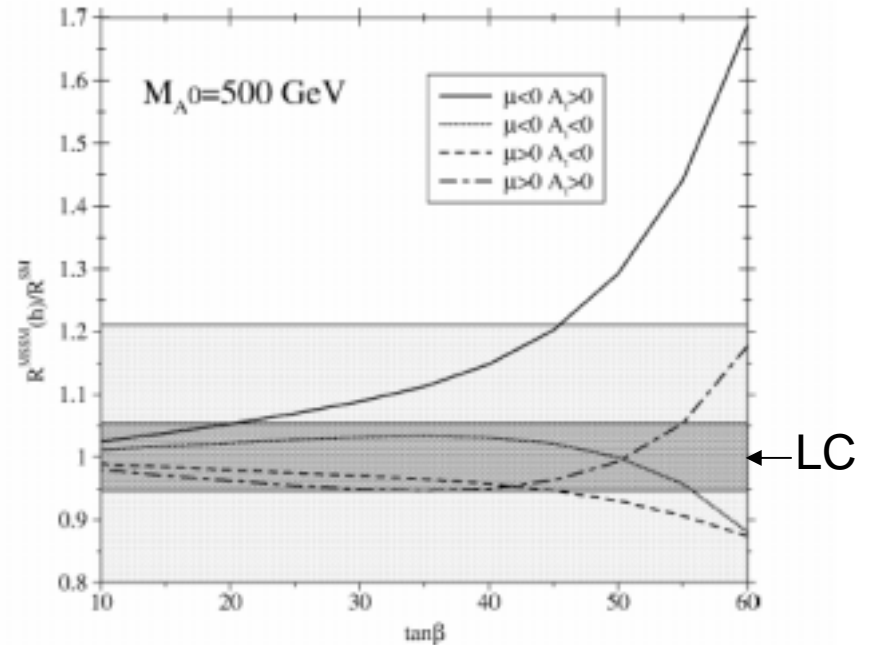

K.S.Babu, C.Kolda:  
M.Carena, D.Garcia, U.Nierste, C.E.M.Wagner

$$M_{\tilde{g}} = M_{\tilde{b}_1} = M_{\tilde{t}_1} = M_{\tilde{\tau}_1} = M_2 = |\mu| = A_b \\ = A_\tau = |A_t| = 1.5 \text{ TeV},$$

J.Guasch, W.Hollik, S.Penaranda

# Higgs self-coupling measurement

Access to the Higgs potential.  
 Precision at  $1/ab$  for 120 GeV Higgs boson  
 ~20% for 500GeV  
 ~10% for 1 TeV

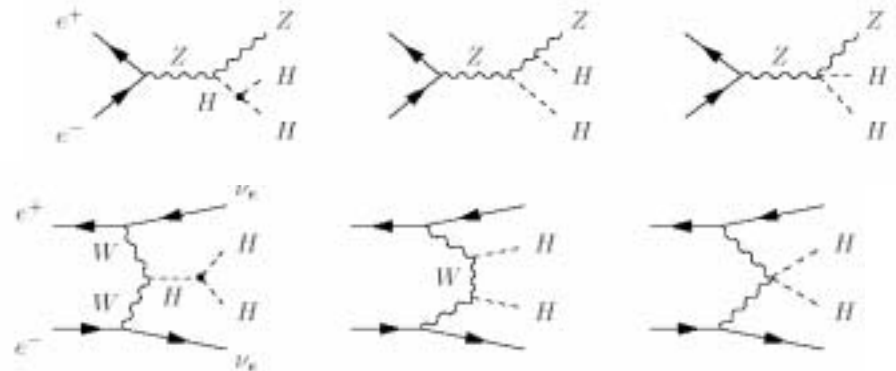

New simulation study at 1 TeV LC

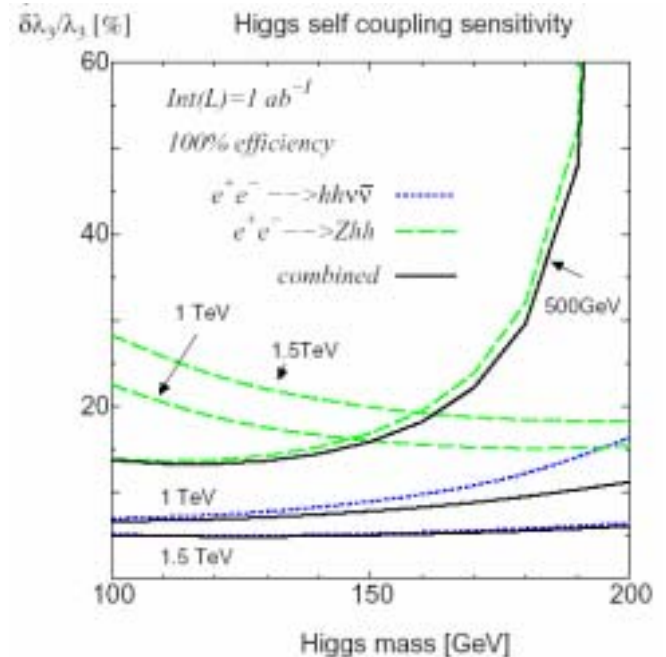
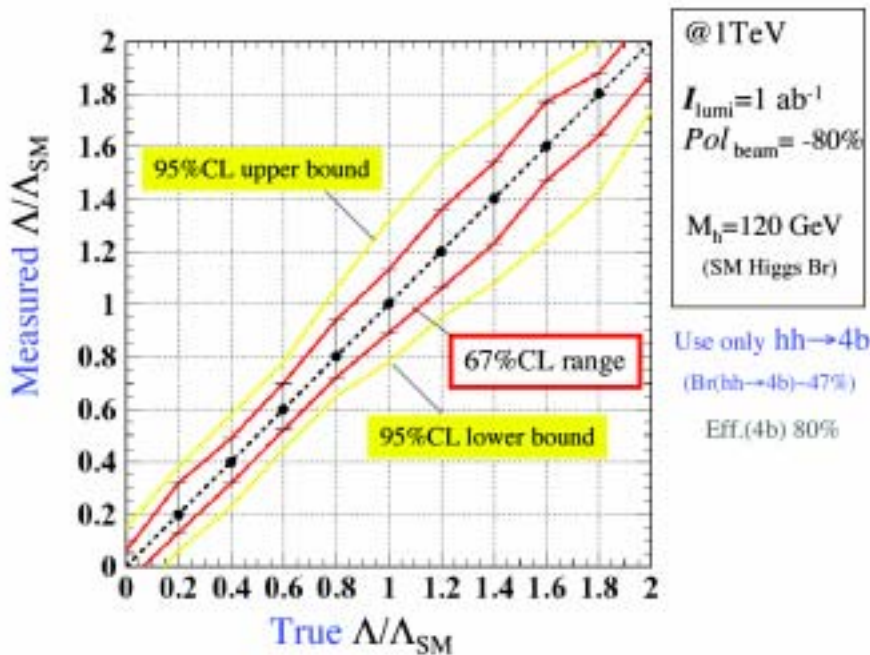

# Electroweak baryogenesis and the radiative correction to the Higgs self coupling constant in 2HDM

The loop correction to the triple Higgs coupling constant becomes large, if the electroweak baryogenesis is realized in 2HDM.

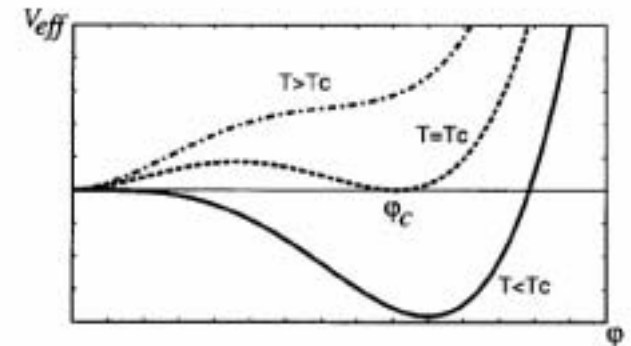

Successful electroweak baryogenesis:  
Strong first order phase transition due to heavy Higgs boson loops.

$$V_T(\phi, T)$$

Large radiative corrections to the zero temperature effective potential.  
A large correction to the triple Higgs coupling constant

$$V_{eff}(\phi)$$

$$m_h = 120 \text{ GeV}, \sin(\alpha - \beta) = -1, \tan\beta = 1$$

$$m_A = M, m_{H^\pm} = m_{H^\pm} + m_\phi$$

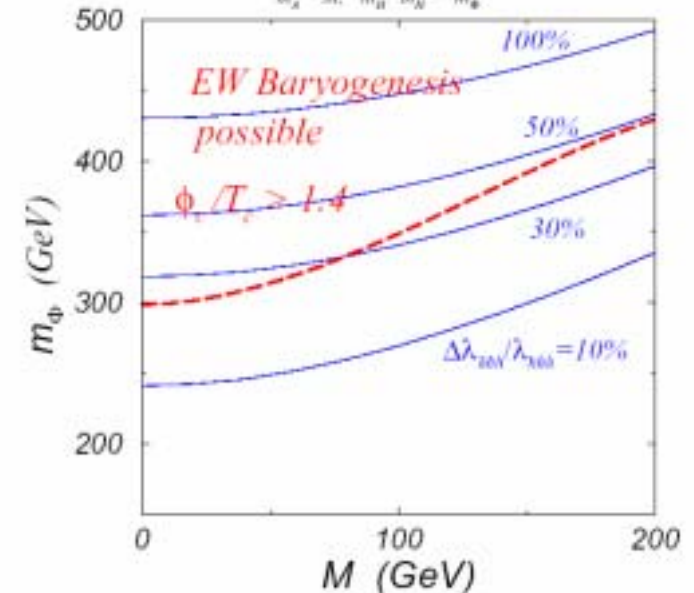

# Direct search for New Physics

- Some type of new signals is expected around 1TeV range, if New Physics is related to a solution of the hierarchy problem. (SUSY, Large extra-dimension, etc )
- The first signal of New Physics is likely to be obtained at Tevatron or LHC. (ex. squarks up to 2.5 TeV at LHC)
- LC experiments are necessary to figure out what new physics is, by measuring spin, quantum numbers, coupling constants of the new particles, and finding lower mass particles which may escape detection at LHC.
- Beam polarization, energy scan, and well-defined initial kinematics play important roles in LC studies.

# SUSY Studies at LC

Various important measurements

1. Determine spin and mass of super partners.  
(Decay angular distribution, threshold scan)
2. Reconstruction of chargino and neutralino sector.
3. Test of slepton-lepton SUSY relations.
4. Test of the GUT relation for sparticles.
5. Determination of SUSY breaking scenario from combined analysis with LHC results.
6. Determine properties of the SUSY dark matter candidate.
7. Search for lepton flavor violation in slepton production and decays.

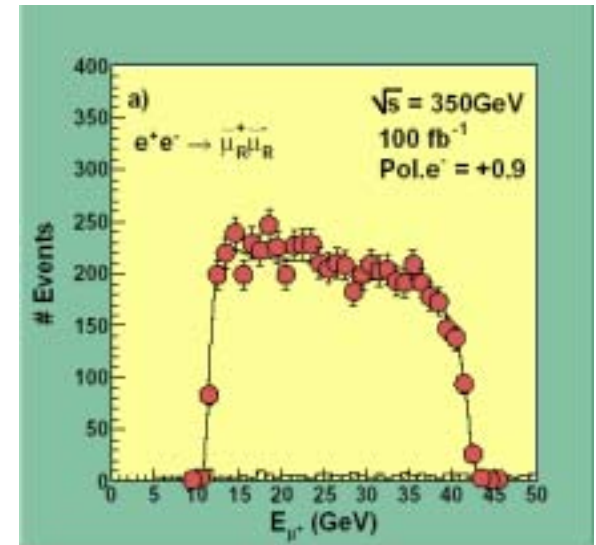

Mass determination to 1% or better

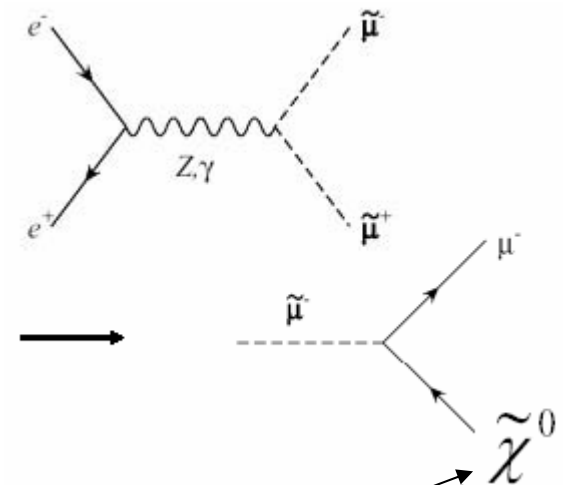

Dark matter candidate

$$Y_B = \frac{g_{\tilde{B}\tilde{e}Re}}{g_{Bee}}$$

# Test of a SUSY relation

Right-handed selectron production

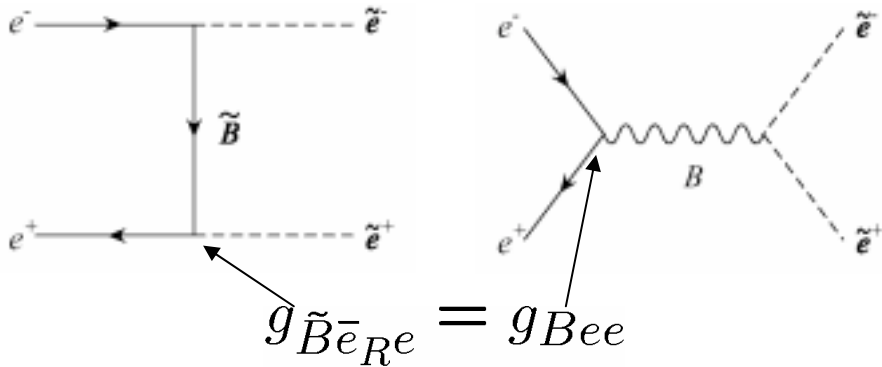

M.M.Nojiri, K.Fujii, and T.Tsukamoto

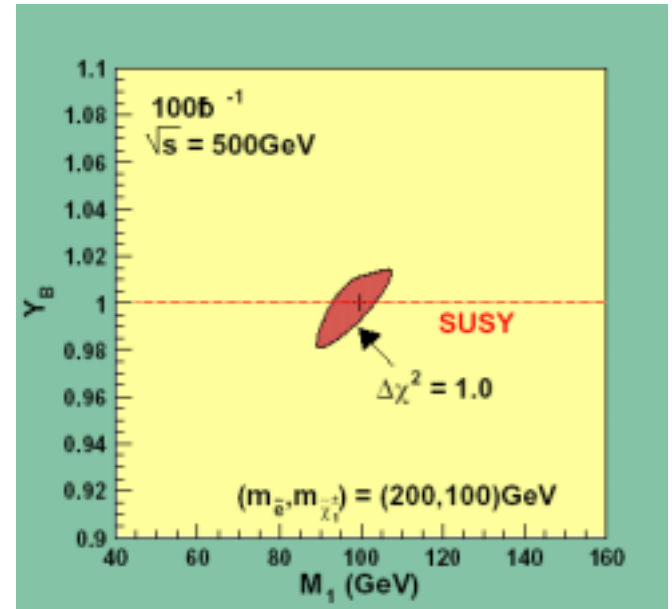

# Test of univarsalities of the SUSY breaking masses with LHC+LC

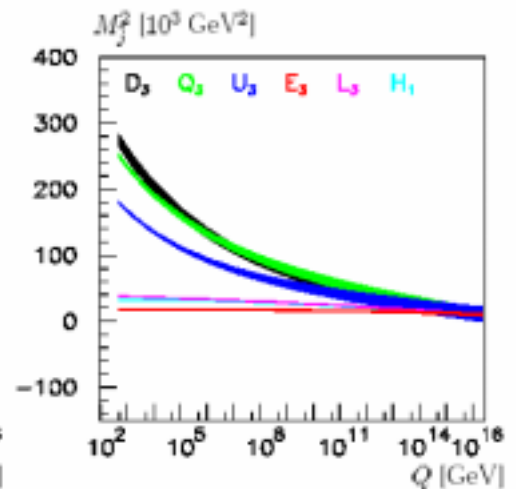
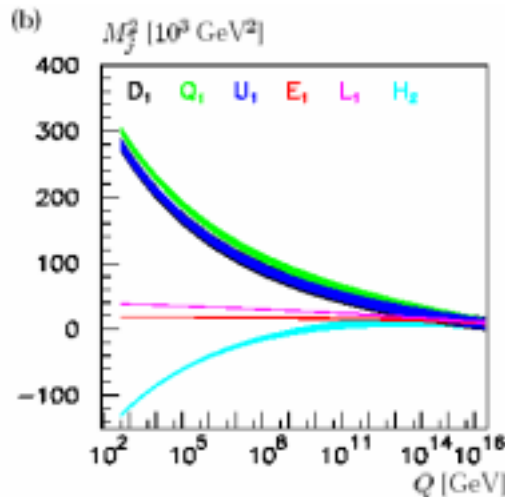
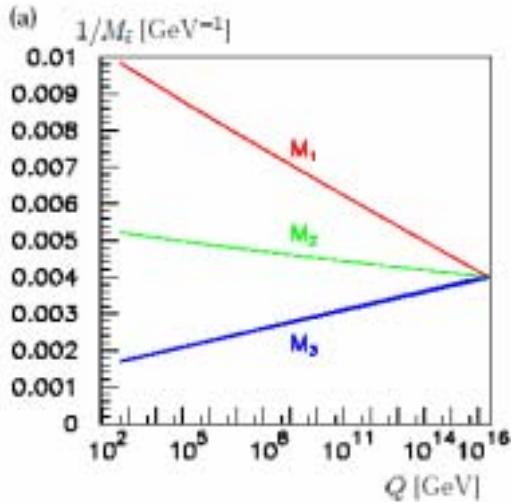

# Dark matter and collider signals

H.Baer, A.Belyaev, T.Krupovnickas, X.Tata

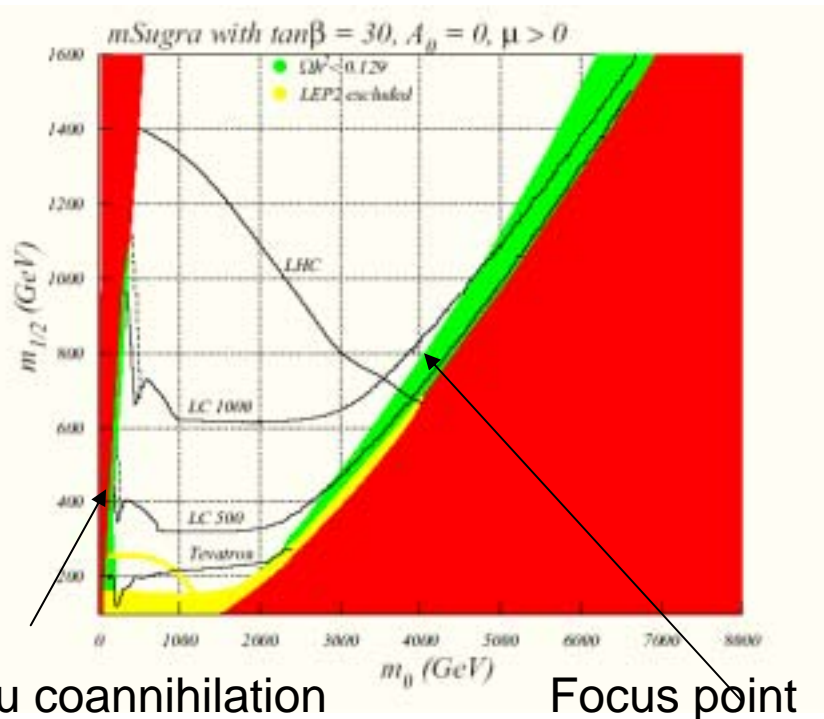

LC can extend the search limit of LHC in the focus point region.

# Lepton flavor violation in SUSY seesaw model

J.Hisano, M.M.Nojiri, Y.Shimizu, M.Tanaka

$$e^+e^- \rightarrow \tilde{l}\tilde{l} \rightarrow \tau\mu X$$

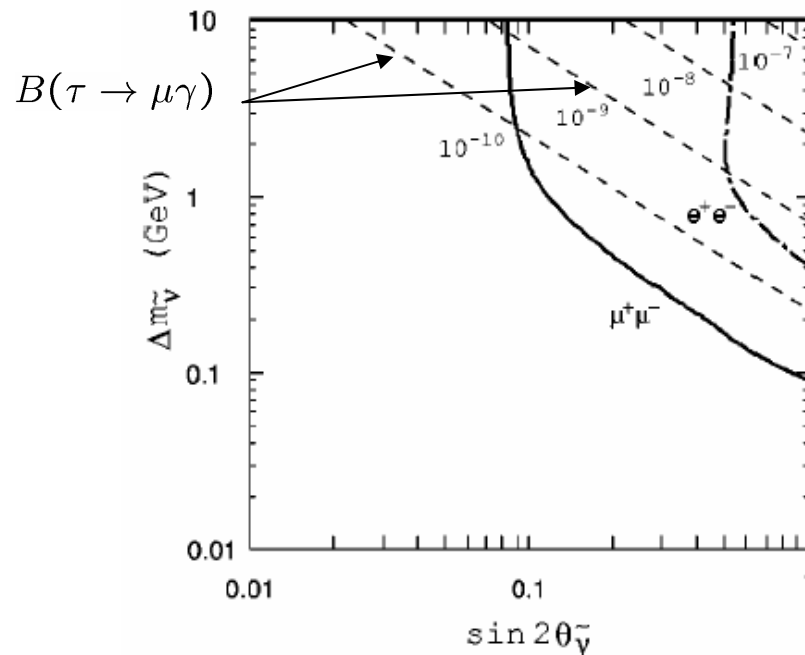

Neutrino mixing -> Slepton mixing  
->LFV slepton production and decay

# Large extra-dimensions

- An alternative solution to the hierarchy problem.
- Spectacular signals are possible at LHC (Black hole production, etc)
- LC is important to clarify the structure of the model.

Size and numbers of extra-dimensions,  
The spin 2 property of Kaluza-Klein gravitons.

Virtual exchange of KK graviton  
in the double Higgs production

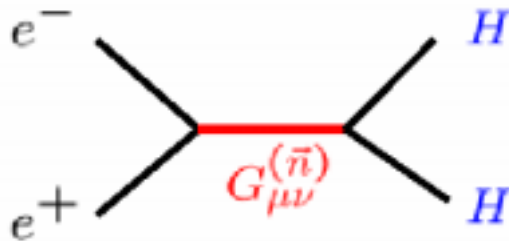

N.Delerue, K.Fujii, N.Okada

$$e^+e^- \rightarrow \gamma + \text{graviton}$$

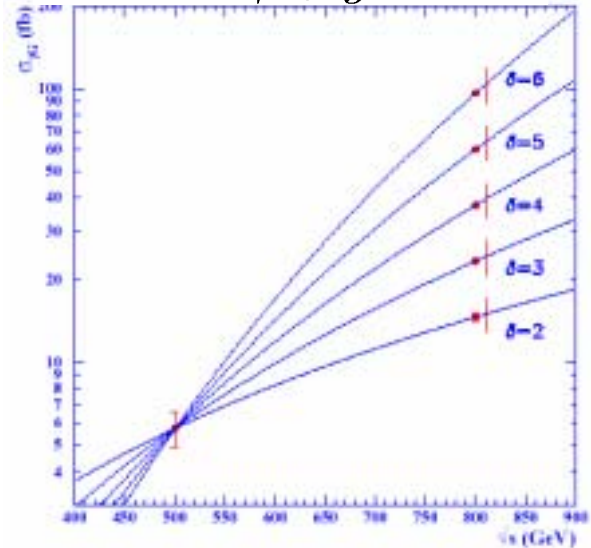

G.W.Wilson

Angular distribution -> Spin 2 exchange

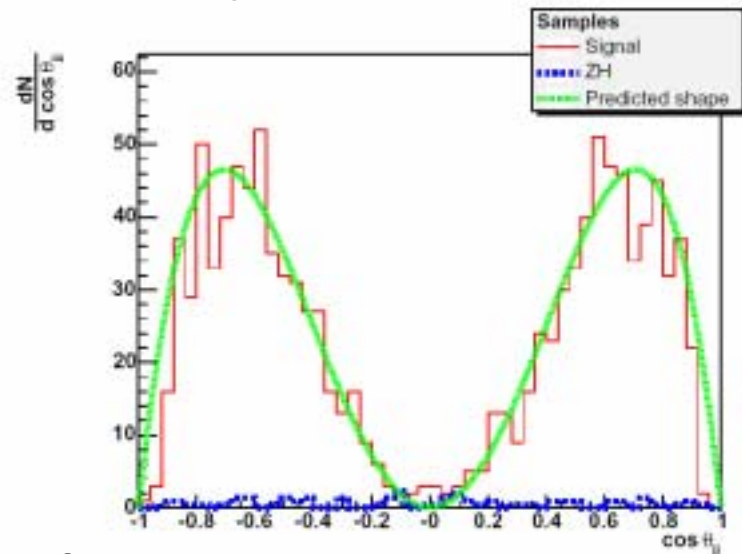

integrated luminosity  $500 \text{ fb}^{-1}$

# Precision measurements of SM processes

- Improve precision of the fundamental parameters.
- Search for new physics in indirect way.

## Top quark threshold scan

The threshold scan improves the top mass measurement and determines the top width.

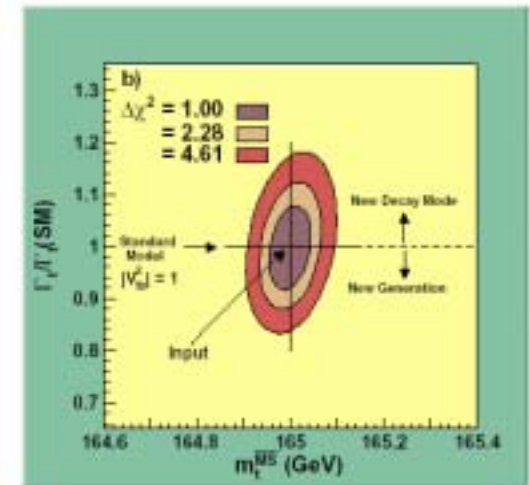
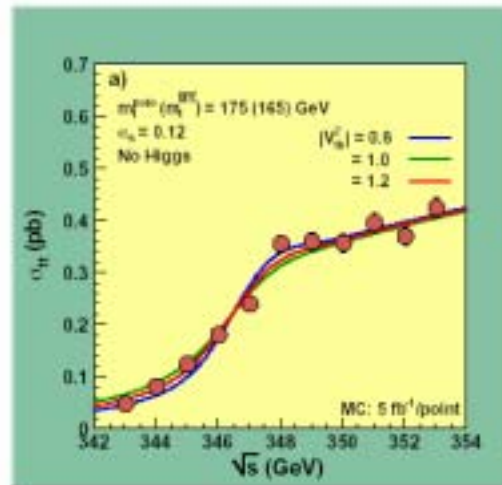

GLC report

# Search for anomalous interaction in $e^+e^- \rightarrow f\bar{f}$ , $WW$ processes

- The search limit at 500 GeV is similar to or better than direct search limit of new particle at LHC in many cases.
- Particularly important when the Higgs boson does not exist or turns out to be unexpectedly heavy.

## Effect of vector resonance in $e^+e^- \rightarrow WW$

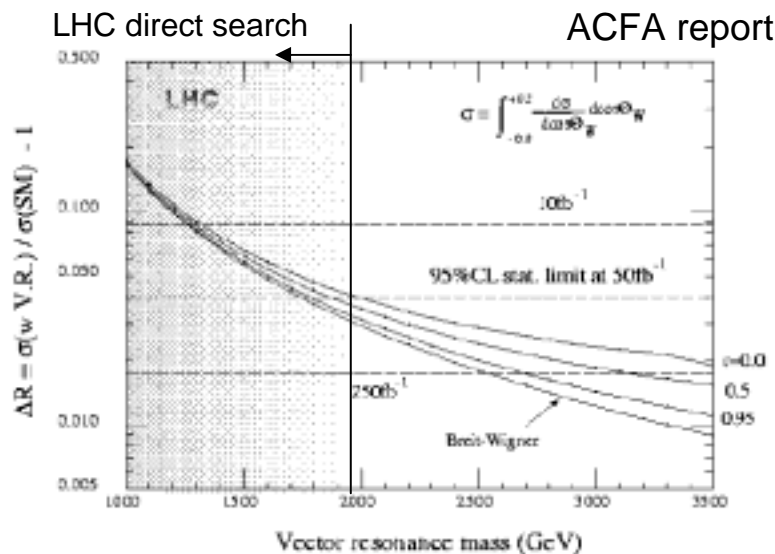

LC 500 GeV can probe the vector resonance up to  $\sim 2$  TeV.

## Z' search

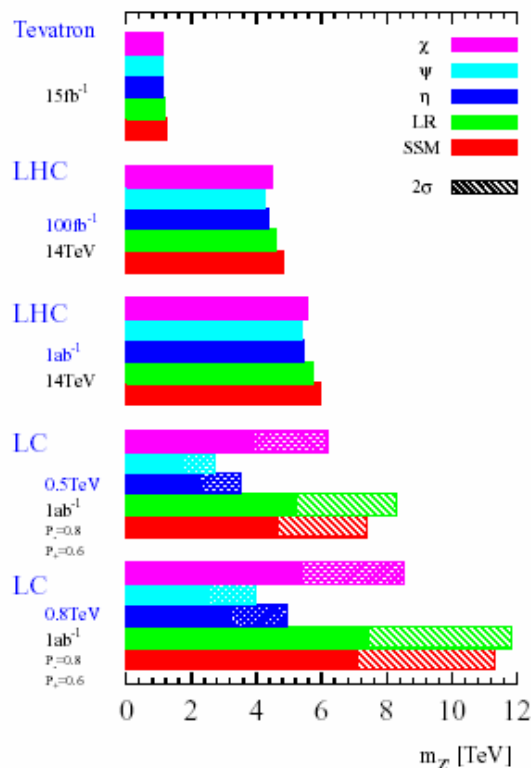

LHC/LC study

# Summary of LC physics

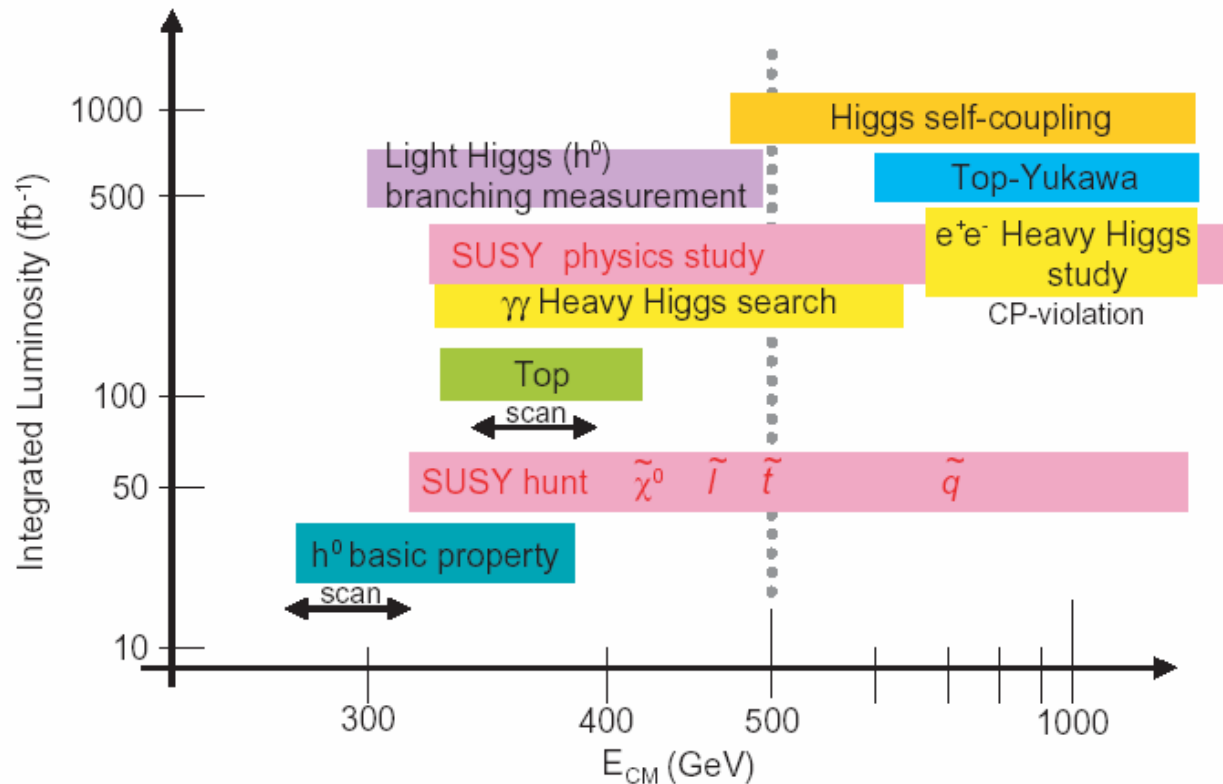

Rich physics programs in the first stage  
 (~ 500 GeV)  
 Energy should be extended to ~ 1 TeV  
 in the second stage.

GLC report

# Conclusions

- Establishing the dynamics of the electroweak symmetry breaking and the mass generation mechanism is the most important next step of the high energy physics. The LC experiment is essential for this purpose.
- The LC experiment will play an important role in finding and studying new physics signals such as SUSY and extra-dimensions. The clean environment, beam polarization, and energy scan are useful for these studies.
- LC is necessary to explore new findings at LHC.